

## Errata

**Title & Document Type:** 1124A Probe Operating Note

**Manual Part Number:** 01124-90904

**Revision Date:** June 1976

### About this Manual

We've added this manual to the Agilent website in an effort to help you support your product. This manual provides the best information we could find. It may be incomplete or contain dated information, and the scan quality may not be ideal. If we find a better copy in the future, we will add it to the Agilent website.

### HP References in this Manual

This manual may contain references to HP or Hewlett-Packard. Please note that Hewlett-Packard's former test and measurement, life sciences, and chemical analysis businesses are now part of Agilent Technologies. The HP XXXX referred to in this document is now the Agilent XXXX. For example, model number HP8648A is now model number Agilent 8648A. We have made no changes to this manual copy.

### Support for Your Product

Agilent no longer sells or supports this product. You will find any other available product information on the Agilent Test & Measurement website:

[www.agilent.com](http://www.agilent.com)

Search for the model number of this product, and the resulting product page will guide you to any available information. Our service centers may be able to perform calibration if no repair parts are needed, but no other support from Agilent is available.



**Agilent Technologies**

OPERATING NOTE/JUNE 1976

**1. DESCRIPTION.**

2. The Model 1124A Probe (Figure 1) provides high voltage, high impedance, general-purpose probing capabilities for 50-ohm input, high-frequency instruments. The probe input RC, 10 megohms shunted by 10 picofarads, prevents circuit loading while a FET (field-effect transistor) circuit provides a bandwidth of dc to 100 MHz. A wide dynamic range, provided in two ranges (X10, X100), allows direct measurements up to 100 volts with either ac or dc coupling. The maximum safe input for the X10 range in the dc-coupled mode is  $\pm 300$  volts (dc plus peak ac) for frequencies below 100 MHz. The X100 range extends the maximum safe input to  $\pm 500$  volts (dc plus peak ac) for frequencies below 100 MHz. The maximum safe input in the ac-coupled mode is the same as for the dc-coupled mode except the dc component of the input signal must not exceed  $\pm 200$  volts.

3. The Model 1124A Probe extends the usefulness of 50-ohm systems such as Hewlett-Packard 183A oscilloscope systems or the Hewlett-Packard Model 8553B/8552A Spectrum Analyzer system by adding general-purpose

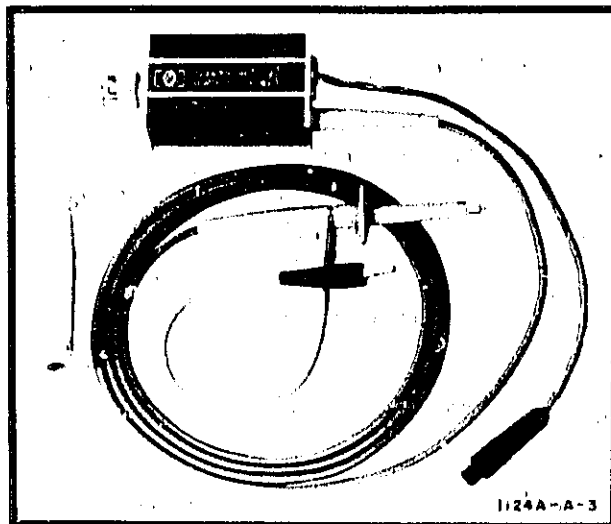

Figure 1. Model 1124A Probe

probing capabilities. The probe can be used with other than 50-ohm systems with a derating of the gain accuracy. Contact the nearest Hewlett-Packard Sales/Service Office for further details concerning use with other systems.

Table 1. Specifications

<p><b>ELECTRICAL CHARACTERISTICS</b> (as measured when connected to 50-ohm load)</p> <p><b>BANDWIDTH</b> (measured from 25-ohm source)                  Dc-coupled: dc to 100 MHz.                  Ac-coupled: 2 Hz to 100 MHz.</p> <p><b>PULSE RESPONSE</b> (measured from 25-ohm source)                  Risetime: &lt; 3.5 ns.                  Perturbations: &lt; 5% p-p.</p> <p><b>ATTENUATION RATIO</b>                  X10: 10:1 <math>\pm</math> 5%.                  X100: 100:1 <math>\pm</math> 5%.</p> <p><b>DYNAMIC RANGE</b>                  X10: <math>\pm</math> 10V.                  X100: <math>\pm</math> 100V.</p> <p><b>INPUT RC</b>                  10 megohms shunted by approximately 10 pF.</p> <p><b>MAXIMUM SAFE INPUT</b>  <b>DC-COUPLED MODE</b>                  X10: <math>\pm</math> 300V (dc + peak ac) <math>\leq</math> 100 MHz.                  X100: <math>\pm</math> 500V (dc + peak ac) <math>\leq</math> 100 MHz.</p>	<p><b>AC-COUPLED MODE</b>                  X10: <math>\pm</math> 300V (dc + peak ac) <math>\leq</math> 100 MHz (dc component must not exceed <math>\pm</math> 200V).                  X100: <math>\pm</math> 500V (dc + peak ac) <math>\leq</math> 100 MHz (dc component must not exceed <math>\pm</math> 200V).</p> <p><b>ACCESSORIES SUPPLIED</b>                  Model 1124A includes one 9-inch ground lead (HP Part No. 10004-61301), one retractable hook tip (HP Part No. 10004-67604) and one probe tip insulator (HP Part No. 10004-45401).</p> <p><b>GENERAL</b></p> <p><b>WEIGHT</b>                  Net: 7 oz (0, 20 kg).                  Shipping: 2 lb (0, 91 kg).</p> <p><b>POWER</b>                  -12.6V and +15V <math>\pm</math> 3% approximately 30 mA from each supply. Normally supplied by 1800-series plug-ins with probe power jacks or Model 1122A Probe Power Supply.</p> <p><b>LENGTH</b>                  Approximately 5 feet over-all.</p>
---	---

Operating Note Part No. 01124-90904  
 Microfiche Part No: 01124-90804



4. Power for the probe is provided by HP oscilloscopes with probe power or with a probe power option, HP oscilloscope plug-in units with probe power, or Remote Sampler Model 1816A. When the probe is operated with other instruments having no probe power, the HP Model 1122A Probe Power Supply must be used as a power source. Refer to Table 1 for complete specifications of the Model 1124A Probe.

### 5. CLAIMS.

6. Upon receipt, inspect the instrument for damage and if none is noted, accomplish the performance checks. If the physical or operating conditions of the instrument are unsatisfactory, notify the carrier and the nearest HP Sales/Service Office immediately. Hewlett-Packard will arrange for repair or replacement without waiting for settlement of the claim by the carrier.

### 7. THEORY OF OPERATION.

8. A high input impedance is essential to prevent circuit loading when measuring high frequency circuits. The sum of the high probe tip resistance and the amplifier input resistance provide the probe input resistance of 10 megohms. Since the probe tip capacitance is in series with the amplifier input capacitance (see Figure 6 for a schematic of the Model 1124A), the shunt capacitance is relatively small (approximately 10 picofarads).

9. Potentiometer R1 on circuit board A1 provides high frequency pulse top adjustment while R2 provides a high frequency corner adjustment. Capacitor C1 provides low frequency corner adjustment for the X10 range.

10. If ac coupling is selected, the signal is coupled through capacitor C2. For dc coupling, C2 is bypassed. When the X10 range is selected, the input is coupled to unity-gain amplifier Q1. When X100 is selected, the signal is coupled through R3 to unity-gain amplifier Q1.

11. When X100 is selected, resistors R3 and R4 form a 10:1 divider. When this divider is added to the 10:1 divider at the input, it provides a 100:1 division ratio.

12. With the ATTENUATION set for X100, variable capacitor C3 shunts the gate of unity-gain amplifier Q1A, providing the X100 low frequency corner adjustment. Resistor R5 in series with capacitor C4 provides high frequency peaking for the X100 range.

13. Unity-gain amplifier Q1A and Q1B along with output driver Q2 form a feedback amplifier. Potentiometer R6 provides input to output 0-volt offset adjustments.

14. The gate circuit of FET Q1A provides a high input impedance to the divider network to prevent circuit loading. The signal on the gate of Q1A is inverted and applied to output driver Q2. By inverting the signal from Q1A, output driver Q2 provides an output voltage of the same polarity as the input.

15. The output voltage from Q2 is applied to the gate of FET Q1B and source followed to the source of Q1A. This negative feedback produces a wide bandwidth and low output impedance.

### 16. PERFORMANCE CHECKS AND ADJUSTMENTS.

17. The performance checks may be used as an incoming inspection or to verify that the instrument meets the specifications listed in Table 1 after repairs or adjustments.

18. Table 2 lists the test equipment necessary to maintain the Model 1124A. Best results are obtained using the equipment listed but similar equipment meeting the required characteristics can be substituted.

### 19. PERFORMANCE CHECKS.

20. Perform the checks in the sequence listed. Succeeding steps are dependent on control settings and results of previous steps. If operation of the Model 1124A does not meet specifications, perform the adjustment procedure in Paragraph 25.

21. GAIN. Connect probe output BNC to monitor oscilloscope channel A input. Connect probe power cord to probe power source. Proceed as follows:

a. Set MODEL 1124A controls as follows:

COUPLING . . . . . DC

ATTENUATION . . . . . X10

b. Connect square-wave generator 50-ohm OUTPUT to monitor oscilloscope channel B input and set controls to obtain a 1-MHz, 5-volt output as monitored on CRT.

c. Disconnect square-wave generator, terminate 50-ohm output with 50-ohm feedthrough termination and probe adapter, and measure output with Model 1124A Probe. Limit:  $0.5 \pm .025$  volt.

d. Set Model 1124A ATTENUATION for X100 and measure output. Limit:  $50 \pm 2.5$  mV.

22. PULSE RESPONSE. Set square-wave generator controls to obtain 3-MHz, 3-volt output pulse (if using HP Model 211B Square Wave Generator, set AMPLITUDE switch for 5-volt range and set vernier for 3-volt output pulse) and proceed as follows:

#### NOTE

Steps a through i provide a simplified procedure for checking pulse response. Steps j through r provide the most accurate procedure for checking pulse response.

a. Set Model 1124A ATTENUATION for X10.

b. Expand monitor oscilloscope time base time/division and measure probe risetime.

Table 2. Recommended Test Equipment

Recommended Instrument		Required Characteristics
Type	Model	
Monitor Oscilloscope Mainframe Vertical Amplifier Time Base	HP 183A HP 1830A HP 1840A	50-ohm input; 250 MHz bandwidth
Square-wave Generator	HP 211B	> 2.5 ns < 5 ns risetime; 3 MHz
50-ohm Feedthrough Termination	HP 10100C	50-ohm termination with BNC connectors
Probe Adapter	HP 10011B	No substitute
50-ohm Tee	HP 10221A	No substitute
50-ohm Load	GR874-W50	50 ohms, GR Type 874 connector
GR874 to Female BNC Adapter	HP 1250-0850	No substitute
Probe Power Supply	HP 1122A	-12.6V, +15V, ground
Sampling Oscilloscope Mainframe TDR/Sampler Sampler	HP 180C HP 1815A HP 1817A	50-ohm input; 1 GHz bandwidth
GR874 to Male BNC Adapter	HP 1250-0849	No substitute
Constant Amplitude Signal Generator	Tektronix Type 191	4V, 1 MHz to 100 MHz constant amplitude.
50-ohm BNC Tee	HP 1250-0781	Male BNC to dual female BNC
X10 ATTENUATOR	HP 8491A, Opt 020	20 dB attenuator
Pulse Generator	HP 8011A	250 ns pulse width, 1 MHz repetition rate, ± 10V output pulse.

c. Disconnect probe from square-wave generator. Disconnect 50-ohm feedthrough and connect square-wave generator output to monitor oscilloscope channel B input.

d. Measure square-wave generator risetime.

e. Calculate probe risetime using following formula:  
Limit: < 3.5 ns

$$R_p = \sqrt{(R_d)^2 - (R_{pg})^2}$$

where:  $R_p$  = risetime of probe  
 $R_d$  = displayed risetime  
 $R_{pg}$  = measured risetime of square-wave generator

f. Disconnect monitor oscilloscope channel B from 50-ohm output and connect 50-ohm feedthrough, probe

adapter and probe to square-wave generator 50-ohm output.

g. Measure pulse top perturbations. Limit: < 5% peak-to-peak.

**NOTE**

Perturbation limits assume a perfectly flat pulse top from the source and a pulse risetime  $\geq$  2.5 ns.

h. Set Model 1124A ATTENUATION for X100 and repeat steps b through f.

- i. Measure pulse top perturbations. Limit:  $< 5\%$  peak-to-peak.

## NOTE

Steps j through r require use of a sampling oscilloscope system to check pulse response.

- j. Connect equipment as shown in Figure 2.

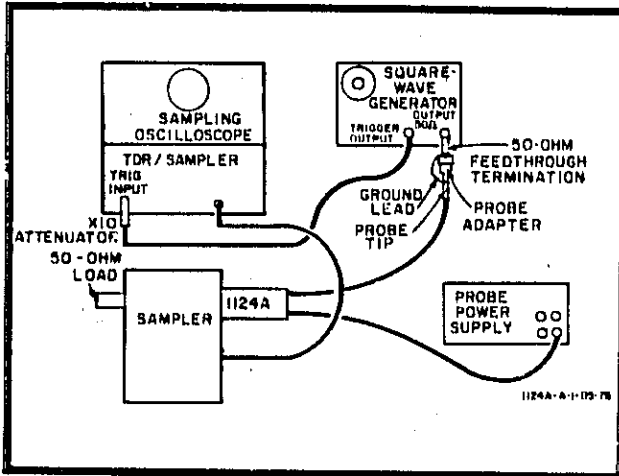

Figure 2. Sampling Oscilloscope Test Setup

- k. Set Model 1124A ATTENUATION for X10.

- l. Set sampling oscilloscope time base trigger for external trigger.

- m. Connect square-wave generator trigger output to sampling oscilloscope time base external trigger input.

- n. Adjust sampling oscilloscope vertical amplifier controls to obtain full-screen display.

- o. Expand sampling oscilloscope time base and calculate probe risetime per step e. Limit:  $< 3.5$  ns.

- p. Measure pulse top perturbations. Limit:  $< 5\%$  peak-to-peak.

## NOTE

Perturbations limits assume a perfectly flat pulse top from the source and a pulse risetime  $\geq 2.5$  ns.

- q. Set Model 1124A ATTENUATION for X100 and repeat steps o and p. Limit:  $< 3.5$  ns.

- r. Measure pulse top perturbations. Limit:  $< 5\%$  peak-to-peak.

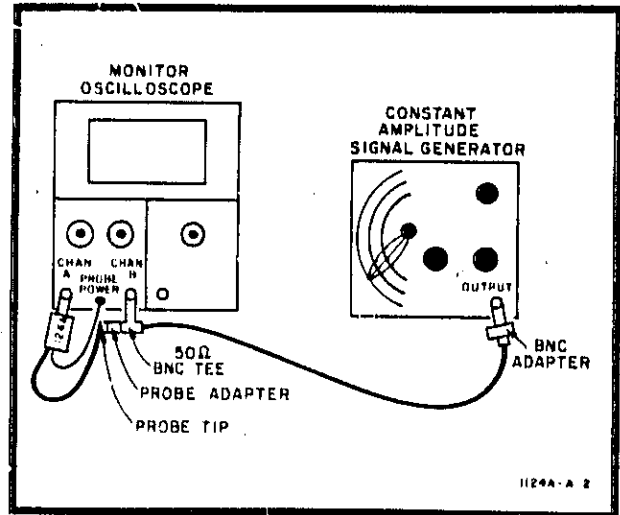

Figure 3. Bandwidth Test Setup

23. BANDWIDTH. Connect equipment as shown in Figure 3 and proceed as follows:

- a. Set constant amplitude signal generator to obtain 4-volt peak-to-peak, 1-MHz sine wave as measured on monitor oscilloscope channel B.

- b. Set Model 1124A ATTENUATION for X10.

- c. Measure probe output on monitor oscilloscope channel A and adjust channel A vernier to obtain 4-division display.

- d. Set constant amplitude signal generator to obtain 4-volt peak-to-peak, 100-MHz sine wave as measured on monitor oscilloscope.

- e. Measure probe output on channel A. Limit:  $\geq .28V$  (.707 x step c reading).

- f. Repeat steps a through e with probe ATTENUATION set for X100. Limit:  $\geq 28$  mV (.707 x step c reading).

24. DYNAMIC RANGE. Connect monitor oscilloscope channel B 50-ohm input through X10 attenuator to pulse generator 50-ohm output. Set Model 1124A ATTENUATION to X10 and proceed as follows:

- a. Set pulse generator to obtain +10-volt, 250 ns wide, 1-MHz output pulse.

- b. Disconnect monitor oscilloscope channel B and X10 attenuator from pulse generator 50-ohm output.

- c. Connect 50-ohm feedthrough and probe adapter to pulse generator 50-ohm output.

- d. Insert probe tip into probe adapter and measure output of probe on monitor oscilloscope CRT. Limit:  $+1 \pm .95V$ .

e. Connect monitor oscilloscope channel B 50-ohm input through X10 attenuator to pulse generator 50-ohm output.

f. Set pulse generator to obtain -10-volt, 250 ns wide, 1-MHz output pulse and repeat steps b through d. Limit:  $-1 \pm .05V$ .

## 25. ADJUSTMENT PROCEDURE.

26. Remove housing from Model 1124A to expose board assembly A1. (See Figure 4 for exploded view of Model 1124A Probe. See Figure 5 for adjustment locations.) Connect probe output BNC to monitor oscilloscope vertical amplifier channel A. Connect probe power cord to probe power source and proceed as follows:

a. Set monitor oscilloscope vertical amplifier for 1 V/div.

b. Set Model 1124A controls as follows:

COUPLING . . . . . DC

ATTENUATION . . . . . X10

c. With no signal input, adjust R6 on board assembly A1 for 0-volt offset as measured on monitor oscilloscope CRT (see Figure 5 for parts and adjustment locations).

d. Set monitor oscilloscope channel A sensitivity for .01 V/div.

e. Adjust R6 on board assembly A1 for  $0 \pm 2$  mV as measured on CRT.

f. Connect square-wave generator 50-ohm output to monitor oscilloscope channel B input. Set controls to obtain 700-Hz, 5-volt output.

g. Remove cable from square-wave generator 50-ohm output, and terminate square-wave generator with 50-ohm feedthrough termination.

h. Connect probe adapter to 50-ohm feedthrough termination.

i. Connect probe tip to probe adapter.

j. Set monitor oscilloscope channel A sensitivity for .1 V/div.

k. Adjust C1 (X10 LF corner adjust) for best corner response as measured with monitor oscilloscope, channel A.

l. Set square-wave generator for 70 kHz output.

m. Set Model 1124A ATTENUATION for X100.

n. Set monitor oscilloscope channel A sensitivity for .01 V/div.

o. Adjust C3 (X100 LF corner adjust) for best corner response.

p. Set square-wave generator for 3 MHz output.

q. Set monitor oscilloscope channel A sensitivity for .1 V/div.

r. Set Model 1124A ATTENUATION for X10.

s. Adjust R1 for flat pulse top.

t. Adjust R2 for best corner response.

u. Repeat steps s and t to obtain best over-all response. (Perturbations < 5% peak-to-peak.)

## 27. REPLACEABLE PARTS

28. Table 3 lists the replaceable parts and identifies the Hewlett-Packard part number of each item. Figure 4 provides an exploded view of the Model 1124A Probe and identifies all the main parts. Figure 5 shows part locations on circuit board A1.

29. To order a replaceable part from Hewlett-Packard, address the order to the nearest Hewlett-Packard Sales/Service Office listed at the rear of this operating note. Include the instrument model number, the reference designator of the part, and the HP Part number. If a part is not listed, provide a description of the part, including function and location.

## 30. SERVICING ETCHED CIRCUIT BOARD

31. The circuit board used in the Model 1124A Probe is made of a special plastic material. The board is very susceptible to melting with high temperature soldering iron tips. Use a soldering iron with a 600° to 700° F tip (Weller W60) or equivalent.

32. The etched circuit board in this instrument has circuitry etched on both sides of the board while components are mounted only on one side. Component mounting holes are plated through for circuit connection between the two sides. Since the mounting holes are plated through, components can be removed by unsoldering from either side of the circuit board (if space permits).

33. The etched circuit board in the Model 1124A is coated with a clear polyurethane for moisture proofing. Components can be removed by heating through the coating with the soldering iron tip. When a component is replaced, respray the affected area on the circuit side with Hysol PC 28 Std. (do not spray component side).

**34. ACCESSORIES AVAILABLE BUT NOT SUPPLIED.**

35. Additional accessories are available for use with the Model 1124A Probe. For further information concerning these accessories, contact the nearest Hewlett-Packard Sales/Service Office. Accessories available are as follows:

- a. All 10004-series probe tips.
- b. HP Model 1122A Power Supply (necessary when vertical plug-in does not have probe power available).
- c. HP 10011B Probe Adapter.

**36. OLDER INSTRUMENTS.**

37. Table 4 lists the changes required to adapt this operating note to cover older instruments. Check your instrument to determine the HP Part Number of circuit board A1. Check Table 4 and make the listed change(s) to the operating note.

Table 4. Operating Note Changes

Circuit Board A1	Make Changes
01124-66501	1
01124-66502	2

**CHANGE 1**

Table 3,

A1C1: Change to HP Part No. 0121-0445; C:var cer  
4.5–20 pF 160 vdcw.

A1C3: Change to HP Part No. 0121-0441; C:var cer  
2–3.5 pF 160 vdcw.

Page 9, Figure 6,

A1C1: Change value to 4.5–20 pF.

A1C3: Change value to 2–3.5 pF

**CHANGE 2**

Table 3,

A1C3: Change to HP Part No. 0121-0060, C:var cer  
2–8 pF  $\pm 0.5$  pF 200 vdcw.

Page 9, Figure 6,

A1C3: Change value to 2–8 pF.

Table 3. Replaceable Parts List

Ref Desig	HP Part No.	TQ	Description
A1	01124-66503	1	A: Impedance Converter Board Assembly
A1C1	0121-0114	1	C: var cer 7-25 pF 160 vdcw
A1C2	0160-3557	1	C: fxd cer 0.01 uF 20% 200 vdcw
A1C3	0121-0467	1	C: var cer 3.0-9.0 pF 100 vdcw
A1C4	0160-3592	1	C: fxd cer 2.4 pF ±0.5 pF 200 vdcw
A1C5	016J-3619	1	C: fxd cer 680 pF 10% 100 vdcw
A1C6	0160-3508	2	C: fxd cer 1 uF +80-20% 50 vdcw
A1C7	0160-3508		C: fxd cer 1 uF +80-20% 50 vdcw
A1CR1	1901-0045	1	CR: Si 100 piv .75A
A1MP1	0340-0709	2	MP: insulator ( 1 each located under A1S1 and A1S2)
A1Q1	1855-0358	1	Q: FET dual
A1Q2	1853-0267	1	Q: si pnp
A1R1	2100-3055	3	R: var cermet lin 500 ohm 10% 1/2W
A1R2	2100-3055		R: var cermet lin 500 ohm 10% 1/2W
A1R3	0757-0488	1	R: fxd metflm 909K ohms 1% 1/8W
A1R4	0698-7284	1	R: fxd metflm 100K ohm 2% 1/8W
A1R5	0698-7264	1	R: fxd metflm 14.7K ohms 2% 1/8W
A1R6	2100-3055		R: var cermet lin 500 ohms 10% 1/2W
A1R7	0698-7242	1	R: fxd metflm 1780 ohm 2% 1/8W
A1R8	0757-0927	1	R: fxd metflm 1300 ohm 2% 1/8W
A1R9	0698-7801	1	R: fxd metflm 500 ohm 2% 1/8W
A1R10	0757-0346	2	R: fxd metflm 10 ohm 1% 1/8W
A1R11	0757-0346		R: fxd metflm 10 ohm 1% 1/8W
A1S1	3101-1518	2	Switch: slide dpdt 0.5A 120V
A1S2	3101-1518	1	Switch: slide dpdt 0.5A 120V
A1VR1	1902-0553	1	VR: breakdown 8.06V 5% 1W
A2	01124-63401	1	A: Probe Tip Attenuator Assembly
A2C1		1	C: nsr p/o A2
A2MP1	10004-24701	1	Spacer: teflon
A2MP2	10004-26101	1	Pin: connector
A2R1		1	R: nsr p/o A2
A2R2		1	R: nsr p/o A2
J1	1250-1232	1	Connector: rf bulkhead
P1			P: nsr p/o W1
P2			P: nsr p/o W2
P3			P: nsr p/o W2
P4	1250-1233	1	Connector: BNC
MP1	7120-2394	1	Label: control identification
MP2	7120-2395	1	Label: name plate
MP3	01124-00201	1	Panel: rear
MP4	01124-20101	1	Chassis
MP5	01124-20401	1	Cover
MP6	01124-60201	2	Vinyl covering
MP7	10004-67701	1	Body: Probe tip
MP8	10004-45402	1	Bushing: strain relief
MP9			Boot: nsr p/o W2
MP10			Boot: nsr p/o W2
W1	01124-61602	1	Cable: power
W2	10006-61601	1	Cable: probe



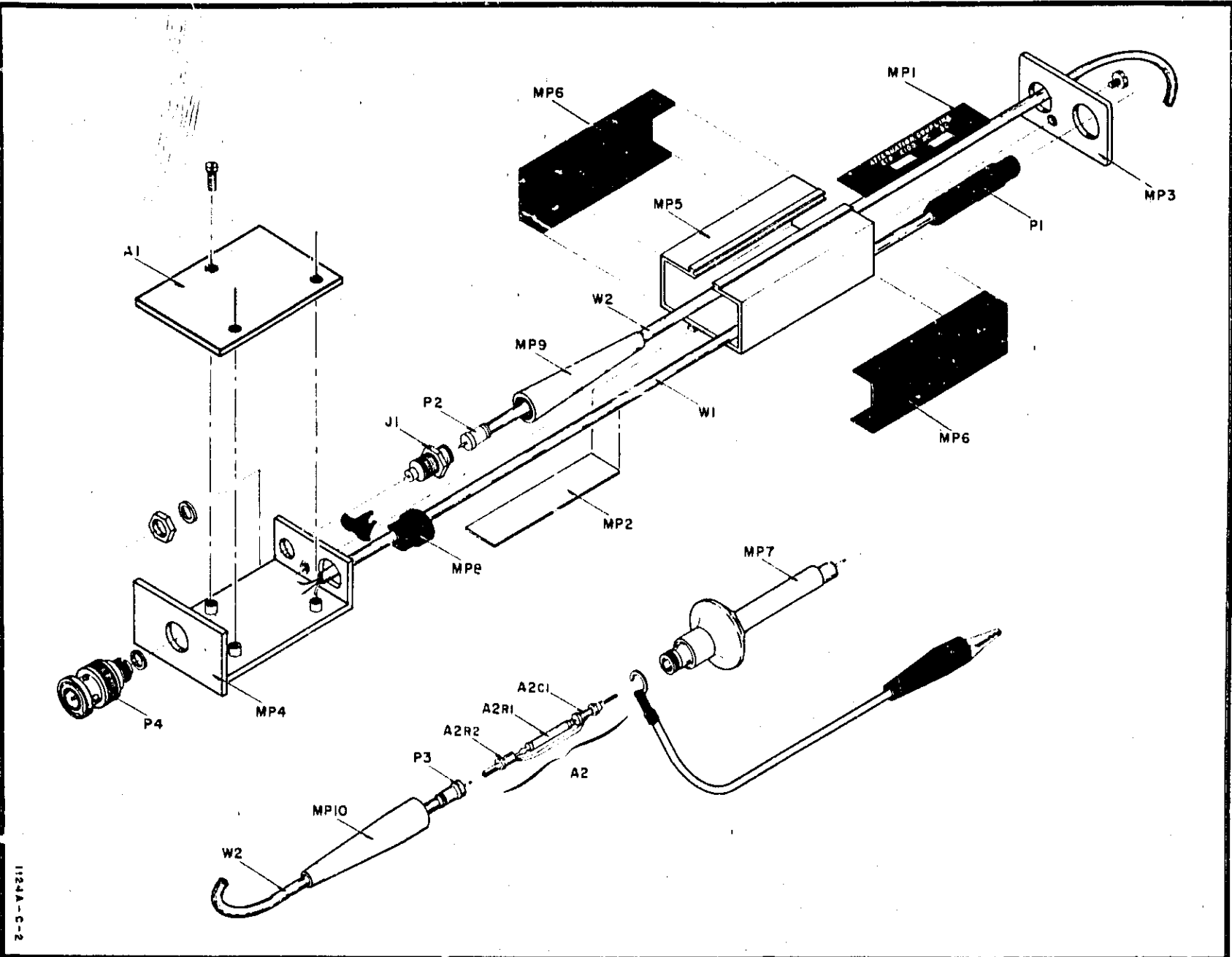
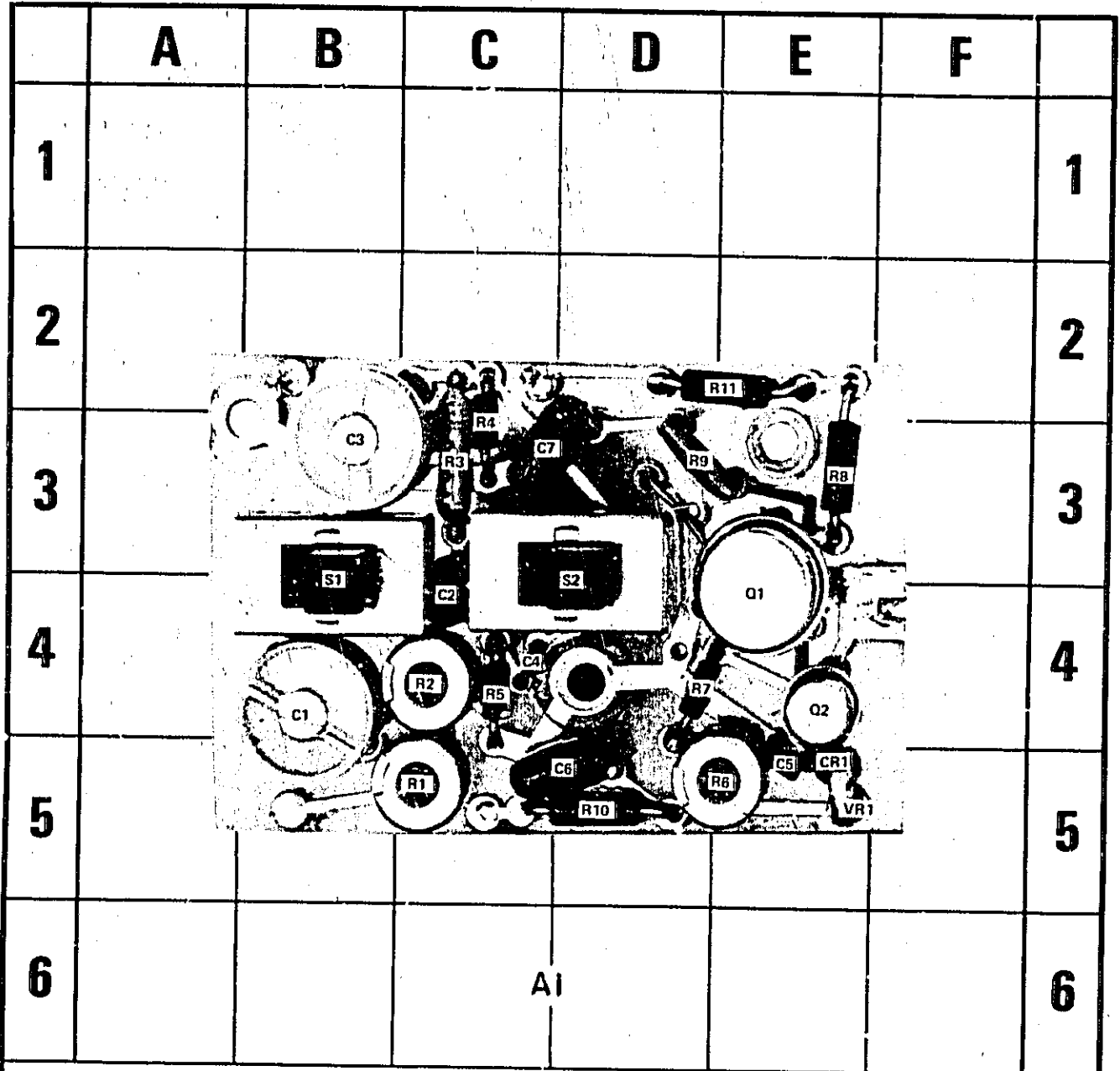

Figure 4. Model 1124A Exploded View

1124A-C-2



REF DESIG	GRID LOC	REF DESIG	GRID LOC
C1	B-4	R3	C-3
C2	C-4	R4	C-3
C3	B-3	R5	C-4
C4	C-4	R6	E-5
C5	E-5	R7	D-4
C6	D-5	R8	E-3
C7	C-3	R9	D-3
CR1	E-5	R10	D-5
Q1	E-4	R11	E-2
Q2	E-4	S1	B-3
R1	C-5	S2	D-3
R2	C-4	VR1	E-5

Figure 5. Circuit Board A1 Component Locations

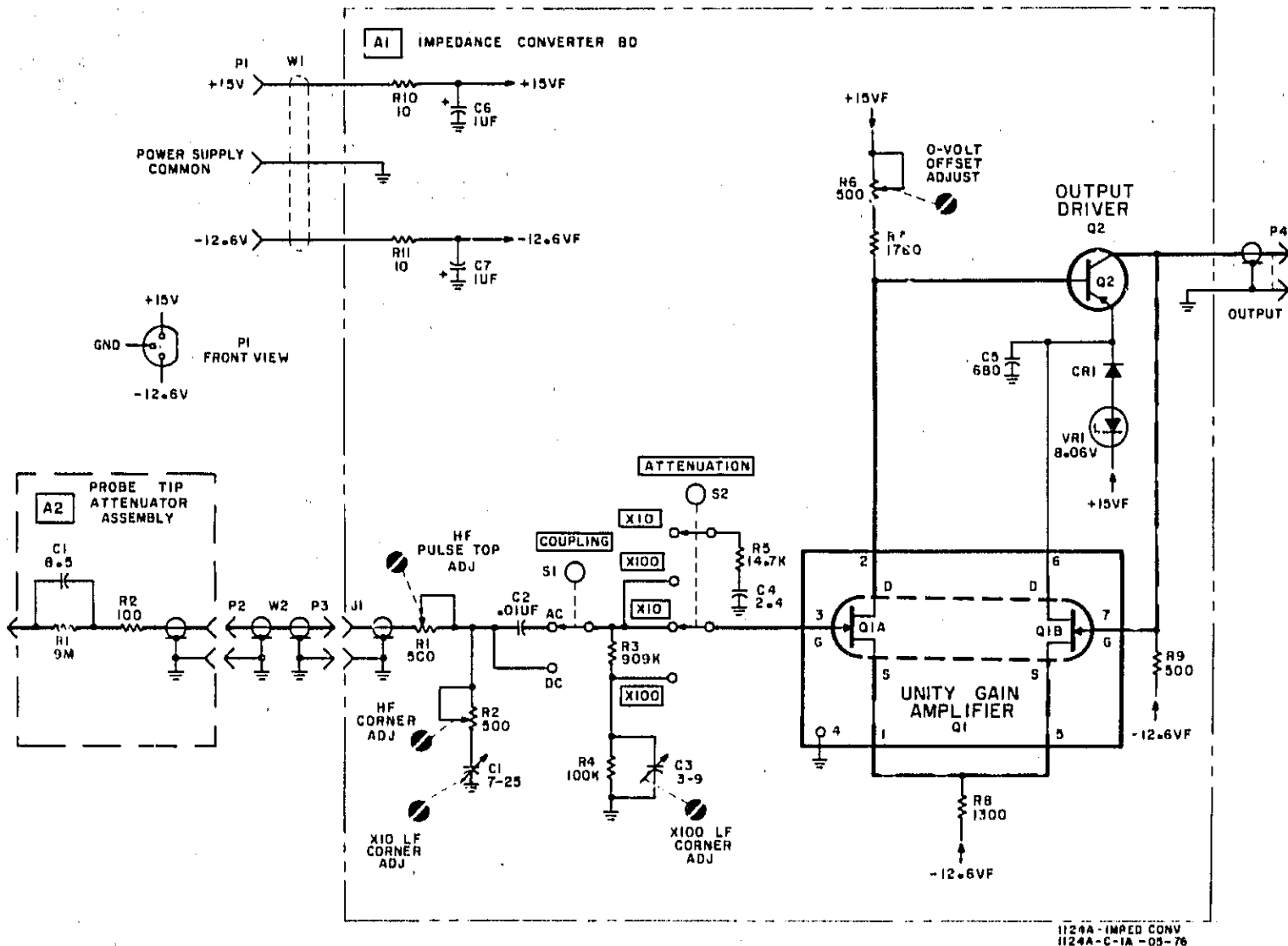

1124A - IMPED CONV  
1124A - C-1A - 05-76

REFERENCE DESIGNATIONS

CHASSIS	A1	A2
P1-4	C1-7, CRI	C1
W1,2	J1, Q1,2	R1,2
	R1-11, S1,2, VRI	

Figure 6. Model 1124A Schematic